

GENERAL FEATURES:

Our Multi-Disc Brakes are hydraulically operated and provide fail-safe characteristics. This means they are normally closed and will release when the necessary hydraulic pressure is applied to the brake port.

They are intended for static braking purposes, for example as a parking or holding brake. However, in the event of emergency also dynamic braking capabilities are given. In this case the brake torque is reduced to approx. 70% of the static value shown in Table 9.

Dynamic braking reduces the life of the brake lining and might also lead to overheating.

In case of frequent dynamic brake cycles please contact Plan-Star Engineering for proper evaluation of your specific case or application.

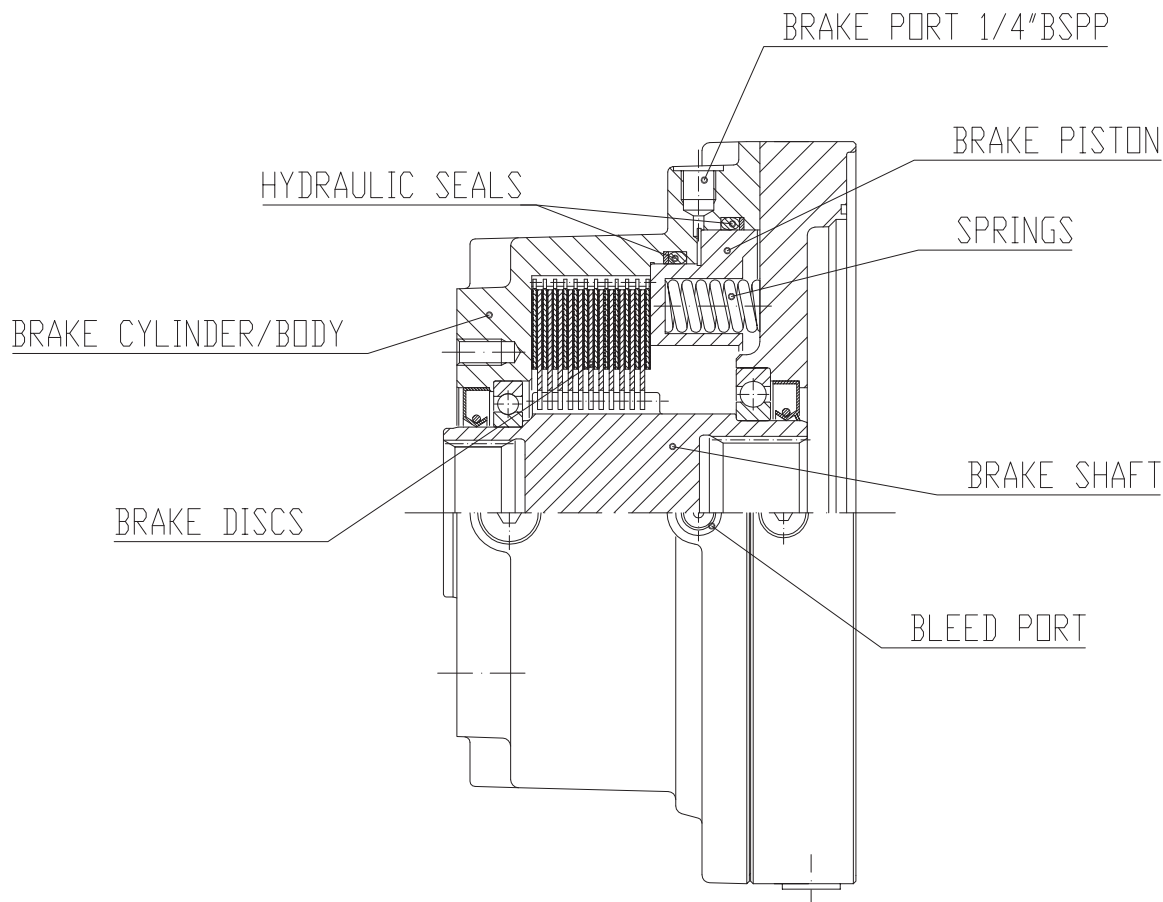

LUBRICATION:

The multi-disc brakes form a compact unit with the gearbox and thus they need very little mounting space.

Their lubrication is of the independent type, but there are also solutions with common lubrication. However, some mounting positions might require lubrication of the common type.

Generally mineral hydraulic oil ISO VG 32 is recommended.

In case of common lubrication of gearbox and brake with synthetic gear oils (e.g. CASTROL Optigear Synthetic X320 and MOBIL Mobilgear SHC XMP 320 or similar) a reduction of the brake torque of up to 15% must be taken into account.

The oil quantities given in the table are valid for horizontal mounting arrangement of the brake (mounting position B5 for In-Line Reducers and mounting positions B5, B53, V1 and V3 for Right-Angle Reducers.

Vertical mounting of the brake (V1 and V2 on In-Line and B51 and B52 on Right-Angle Units) require approximately doubled oil quantities.

SELECTION:

The correct selection of the brake is depending not only on the required brake torque and the release pressure. It is further of crucial importance to make sure that the static brake torque multiplied with the gearbox ratio will not exceed the admissible peak torque of the gearbox (see relevant gear ratio in Annex "C"). Also the efficiency has a certain influence as it increases the brake capacity, see Section B4, Table 2.

The resulting brake torque can be calculated as follows:

$$T_{2Br} = T_{St} \times u \times \frac{1}{\eta} \quad \text{formula 11}$$

When selecting a brake-gearbox combination the following condition must be fulfilled:

$$T_{2Br} \leq T_{2peak} \quad \text{formula 12}$$

Table 12, Static Brake Torque T_{St}

Type	Static Torque ^①		Release Press.		Max. Pressure ^②		Oil Volume ^③		Release Vol. ^④		Type	Static Torque ^①		Release Press.		Max. Pressure ^②		Oil Volume ^③		Release Vol. ^④		
	[Nm]	[ft-lb]	[bar]	[psi]	[bar]	[psi]	[ccm]	[cu.in]	[ccm]	[cu.in]		[Nm]	[ft-lb]	[bar]	[psi]	[bar]	[psi]	[ccm]	[cu.in]	[ccm]	[cu.in]	
1 AC	799	589	23.5	340	125	1800	50	3.1	15	0.9	4 AA	10000	7380	33	480	125	1800	400	24.4	54	3.3	
1 AE	559	412	16.5	240	125	1800	50	3.1	15	0.9	4 AB	9000	6640	30	435	125	1800	400	24.4	54	3.3	
1 AF	374	276	11	160	125	1800	50	3.1	15	0.9	4 AC	8400	6200	27.5	400	125	1800	400	24.4	54	3.3	
1 AH	267	197	8	115	125	1800	50	3.1	15	0.9	4 AD	7800	5750	25.5	370	125	1800	400	24.4	54	3.3	
1 AK	187	138	5.5	80	125	1800	50	3.1	15	0.9	4 AE	6700	4940	22	320	125	1800	400	24.4	54	3.3	
1 CA	745	550	33	480	125	1800	50	3.1	15	0.9	4 AF	5600	4130	18.5	270	125	1800	400	24.4	54	3.3	
1 CC	532	392	23.5	340	125	1800	50	3.1	15	0.9	4 AG	5000	3690	16.5	240	125	1800	400	24.4	54	3.3	
1 CE	373	275	16.5	240	125	1800	50	3.1	15	0.9	4 AH	4500	3320	14.5	210	125	1800	400	24.4	54	3.3	
1 CF	250	184	11	160	125	1800	50	3.1	15	0.9	4 AJ	3300	2430	11	160	125	1800	400	24.4	54	3.3	
1 CH	178	131	8	115	125	1800	50	3.1	15	0.9	4 CA	7500	5530	33	480	125	1800	400	24.4	54	3.3	
1 CK	125	92	5.5	80	125	1800	50	3.1	15	0.9	4 CC	6300	4650	27.5	400	125	1800	400	24.4	54	3.3	
1 EA	373	275	33	480	125	1800	50	3.1	15	0.9	4 CD	5900	4350	25.5	370	125	1800	400	24.4	54	3.3	
1 EC	266	196	23.5	340	125	1800	50	3.1	15	0.9	4 CF	4200	3100	18.5	270	125	1800	400	24.4	54	3.3	
1 EE	186	137	16.5	240	125	1800	50	3.1	15	0.9	4 CG	3800	2800	16.5	240	125	1800	400	24.4	54	3.3	
1 EF	125	92	11	160	125	1800	50	3.1	15	0.9	4 EF	2800	2060	18.5	270	125	1800	400	24.4	54	3.3	
1 EH	89	66	8	115	125	1800	50	3.1	15	0.9	4 EG	2500	1840	16.5	240	125	1800	400	24.4	54	3.3	
1 EK	62	46	5.5	80	125	1800	50	3.1	15	0.9												
Type	Static Torque ^①		Release Press.		Max. Pressure ^②		Oil Volume ^③		Release Vol. ^④		Type	Static Torque ^①		Release Press.		Max. Pressure ^②		Oil Volume ^③		Release Vol. ^④		
	[Nm]	[ft-lb]	[bar]	[psi]	[bar]	[psi]	[ccm]	[cu.in]	[ccm]	[cu.in]		[Nm]	[ft-lb]	[bar]	[psi]	[bar]	[psi]	[ccm]	[cu.in]	[ccm]	[cu.in]	
2 AA	1118	825	33	480	125	1800	50	3.1	15	0.9	5 AA	10000	7380	33	480	125	1800	400	24.4	54	3.3	
2 AC	799	589	23.5	340	125	1800	50	3.1	15	0.9	5 AB	9000	6640	30	435	125	1800	400	24.4	54	3.3	
2 AE	559	412	16.5	240	125	1800	50	3.1	15	0.9	5 AC	8400	6200	27.5	400	125	1800	400	24.4	54	3.3	
2 AF	374	276	11	160	125	1800	50	3.1	15	0.9	5 AD	7800	5750	25.5	370	125	1800	400	24.4	54	3.3	
2 AH	267	197	8	115	125	1800	50	3.1	15	0.9	5 AE	6700	4940	22	320	125	1800	400	24.4	54	3.3	
2 AK	187	138	5.5	80	125	1800	50	3.1	15	0.9	5 AF	5600	4130	18.5	270	125	1800	400	24.4	54	3.3	
2 CA	745	550	33	480	125	1800	50	3.1	15	0.9	5 AG	5000	3690	16.5	240	125	1800	400	24.4	54	3.3	
2 CC	532	392	23.5	340	125	1800	50	3.1	15	0.9	5 AH	4500	3320	14.5	210	125	1800	400	24.4	54	3.3	
2 CE	373	275	16.5	240	125	1800	50	3.1	15	0.9	5 AJ	3300	2430	11	160	125	1800	400	24.4	54	3.3	
2 CF	250	184	11	160	125	1800	50	3.1	15	0.9	5 CA	7500	5530	33	480	125	1800	400	24.4	54	3.3	
2 CH	178	131	8	115	125	1800	50	3.1	15	0.9	5 CC	6300	4650	27.5	400	125	1800	400	24.4	54	3.3	
2 CK	125	92	5.5	80	125	1800	50	3.1	15	0.9	5 CD	5900	4350	25.5	370	125	1800	400	24.4	54	3.3	
2 EA	373	275	33	480	125	1800	50	3.1	15	0.9	5 CF	4200	3100	18.5	270	125	1800	400	24.4	54	3.3	
2 EC	266	196	23.5	340	125	1800	50	3.1	15	0.9	5 CG	3800	2800	16.5	240	125	1800	400	24.4	54	3.3	
2 EE	186	137	16.5	240	125	1800	50	3.1	15	0.9	5 EF	2800	2060	18.5	270	125	1800	400	24.4	54	3.3	
2 EF	125	92	11	160	125	1800	50	3.1	15	0.9	5 EG	2500	1840	16.5	240	125	1800	400	24.4	54	3.3	
2 EH	89	66	8	115	125	1800	50	3.1	15	0.9												
2 EK	62	46	5.5	80	125	1800	50	3.1	15	0.9												
Type	Static Torque ^①		Release Press.		Max. Pressure ^②		Oil Volume ^③		Release Vol. ^④		Type	Static Torque ^①		Release Press.		Max. Pressure ^②		Oil Volume ^③		Release Vol. ^④		
	[Nm]	[ft-lb]	[bar]	[psi]	[bar]	[psi]	[ccm]	[cu.in]	[ccm]	[cu.in]		[Nm]	[ft-lb]	[bar]	[psi]	[bar]	[psi]	[ccm]	[cu.in]	[ccm]	[cu.in]	
3 AA	3830	2825	29.5	430	125	1800	220	13.4	21	1.3												
3 AB	3070	2265	23.5	340	125	1800	220	13.4	21	1.3												
3 AC	2880	2125	22	320	125	1800	220	13.4	21	1.3												
3 AD	2300	1695	17.5	255	125	1800	220	13.4	21	1.3												
3 AE	1920	1415	14.5	210	125	1800	220	13.4	21	1.3												
3 AF	1530	1130	12	175	125	1800	220	13.4	21	1.3												
3 AG	960	710	7.5	110	125	1800	220	13.4	21	1.3												
3 DC	1920	1415	22	320	125	1800	220	13.4	21	1.3												
3 DD	1530	1130	17.5	255	125	1800	220	13.4	21	1.3												
3 DE	1280	945	14.5	210	125	1800	220	13.4	21	1.3												
3 DF	1020	750	12	175	125	1800	220	13.4	21	1.3												
3 GC	960	710	22	320	125	1800	220	13.4	21	1.3												
3 GD	770	570	17.5	255	125	1800	220	13.4	21	1.3												
3 GE	640	470	14.5	210	125	1800	220	13.4	21	1.3												
3 GF	510	375	12	175	125	1800	220	13.4	21	1.3												
3 GG	320	235	7.5	110	125	1800	220	13.4	21	1.3												

- ① ±10%, new brake discs, mineral oil ISO VG32, no back pressure.
- ② Max. pressure 250 bar / 3600 psi available on request.
- ③ Approximate quantity of lubrication oil, horizontal mounting.
- ④ Maximum oil volume needed to fully release the brake.

Availability, Multi-Disc Brakes

Data and dimensions are not binding and may be modified without prior notice

		Gearbox Model							
Gearbox Size		In-Line						Size	Right-Angle
15	15 L1-L4								
18	18 L1-L4								
22	22 L1-L4								
28	28 L1-L4								
32	32 L1-L4								
36	36 L2-L4	36 L1					36	36 R2-R4	
42	42 L2-L4	42 L1					42	42 R2-R4	
50	50 L2-L4	50 L1					50	50 R2-R4	
60	60 L2-L4	60 L1					60	60 R2-R4	
67	67 L2-L4	67 L1					67	67 R2-R4	
75	75 L3-L4	75 L2	75 L1				75	75 R2-R4	
85	85 L3-L4	85 L2	85 L1				85	85 R2-R4	
100	100 L3-L4	100 L2	100 L1				100	100 R2-R4	
110	110 L3-L4	110 L2	110 L1				110	110 R2-R4	
130	130 L3-L4	130 L2	130 L1				130	130 R2-R4	
140	140 L3-L4	140 L2		140 L1			140	140 R2-R4	
170	170 L3-L4	170 L2		170 L1			170	170 R2-R4	
200	200 L4	200 L3	200 L2	200 L1			200	200 R3-R4 200 R2	
220	220 L4	220 L3	220 L2	220 L1			220	220 R3-R4 220 R2	
260	260 L4	260 L3	260 L2	260 L1			260	260 R3-R4 260 R2	
300	300 L4	300 L3	300 L2		300 L1		300	300 R3-R4 300 R2	
360	360 L4	360 L3		360 L2		360 L1	360	360 R3-R4 360 R2	
420	420 L4	420 L3		420 L2		420 L1	420	420 R3-R4 420 R2	
480	480 L4	480 L3		480 L2		480 L1	480	480 R3-R4 480 R2	
560		560 L4	560 L3	560 L2		560 L1	560	560 R4 560 R2-R3	
630		630 L4	630 L3	630 L2		630 L1	630	630 R4 630 R3	
750		750 L4	750 L3		750 L2		750	750 R4 750 R3	
900		900 L4	900 L3		900 L2		900	900 R4 900 R3	
1100		1100 L4		1100 L3		1100 L2	1100	1100 R4 1100 R3	
1300		1300 L4		1300 L3		1300 L2	1300	1300 R4 1300 R3	
1700			1700 L4	1700 L3		1700 L2			
2100			2100 L4		2100 L3				
2500			2500 L4		2500 L3				

Type	Distance 'x' [mm]		approx. mass [kg]	approx. mass [lbs]
1 ..	Standard, Other Motors	85.5 ^{17.3} / _{38.1}		
	GM-05 Direct Mount "F15"	112.5 ^{17.3} / _{38.1}		
	GM-01 Direct Mount "F11"	85.5 ^{17.3} / _{38.1}		
2 ..	Standard, Other Motors	85 ^{17.3} / _{38.1}		
	GM-01 Direct Mount "F21"	93 ^{17.3} / _{38.1}		
	GM-02 Direct Mount "F22"	116 ^{21.7} / _{47.8}		
3 ..	Standard, Other Motors	148 ³⁵ / ₇₇		
	GM-01 Direct Mount "F31"	171 ⁴⁰ / ₈₈		
	GM-02 Direct Mount "F32"	171 ⁴² / ₉₃		
4 ..	GM-04 Direct Mount "F54"		194 ⁷⁶ / ₁₆₈	
5 ..	GM-04 Direct Mount "F54"		136.5 ⁶² / ₁₃₇	125.5 ⁶⁰ / ₁₃₂
	GM-06 Direct Mount "F56"		147.5 ⁷¹ / ₁₅₇	136.5 ⁶⁹ / ₁₅₂

Type	Distance 'x' [mm]		approx. mass [kg]	approx. mass [lbs]
1 ..	Standard, Other Motors	85.5 ^{17.3} / _{38.1}		
	GM-01 Direct Mount "F11"	85.5 ^{17.3} / _{38.1}		
3 ..	Standard, Other Motors	148 ³⁵ / ₇₇		
	GM-01 Direct Mount "F31"	171 ⁴⁰ / ₈₈		
	GM-02 Direct Mount "F32"	171 ⁴² / ₉₃		

Mounting Scheme, In-Line Gears

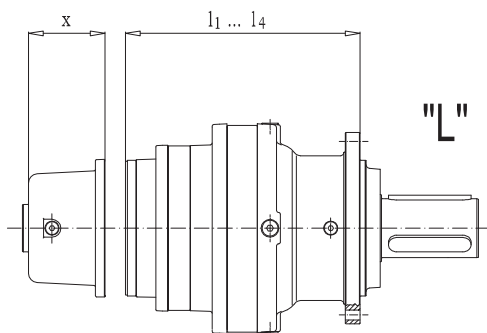

Mounting Scheme, Right-Angle Gears

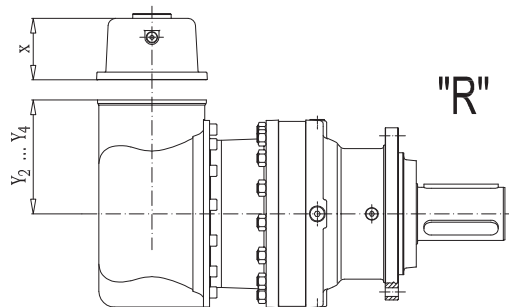

Data and dimensions are not binding and may be modified without prior notice